

MELBOURNE 2-TIER PENDANT

MARY WALLIS



MELBOURNE 2-TIER PENDANT

MARY WALLIS

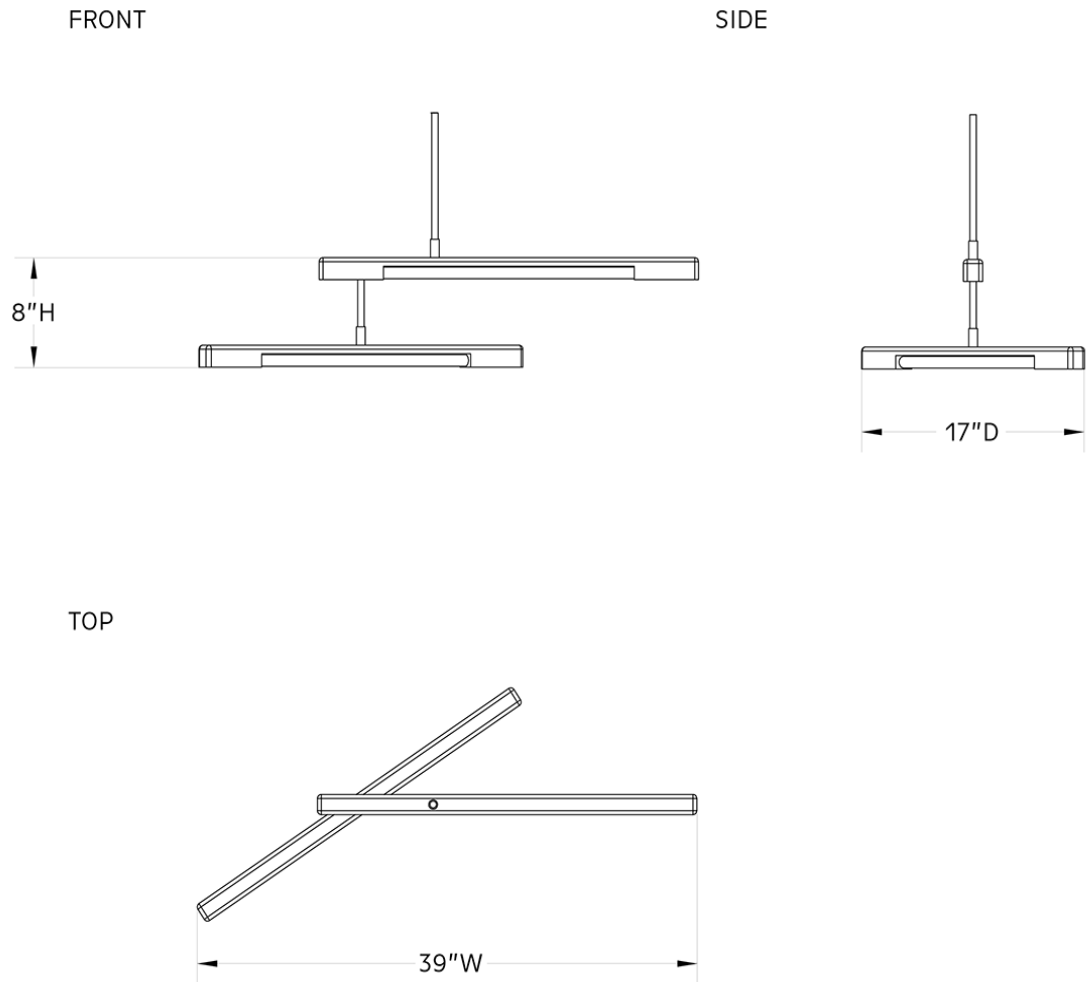

DESIGNER
Mary Wallis

ORIGIN
United States

PRODUCTION
Made to Order

WEIGHT
10 lbs.

CERTIFICATIONS
UL.

MATERIALS
Aluminum hardware, available in satin nickel or matte black finish. Glass shades.

DIMENSIONS
Canopy: Dia. 5.5" x H 2"
Fixture: L 39" x W 17" x H 8"
Overall Height: Site adjustable up to 46"

ILLUMINATION
12V LED, 2400K, dimmable, transformer supplied.

SUSPENSION
A 36" site-adjustable stem is included with purchase. The aluminum stem will come in matching metal finish. Maximum length 72" upon request.